

CONSERVATOR AND LIBRARIAN/by Don Etherington

INTRODUCTION: The following short article was an introduction to a lecture given at a meeting of the Rare Books and Manuscripts Section of the American Library Association in Los Angeles the summer of 1983.

The premise of the lecture was to establish and renew good relationships between conservators and librarians, scholars and collectors of books and manuscripts. Out of the ensuing discussion came a plea for more information so that they could be more helpful. The first step taken in this endeavor was to present the subject of collation practices used by book conservators. The document outlining those procedures was then sent to Daniel Traister, Special Collections Librarian at the University of Pennsylvania who is helping to compile material for publication in College and Research Libraries.

This idea will hopefully be continued on other subjects of equal interest. This is where the conservator of rare books and manuscripts can be of immense help. If there are any subjects that would be of interest for discussion, please write to me and let's keep this pipeline open for a healthy development for our field and bring the curator/custodian of rare books and manuscript collections into the conservation arena. This system will allow us all to make a much more valued judgement or choice of treatment and/or non-treatment to the valuable artifacts that come our way.

## CONSERVATOR AND LIBRARIAN

BACKGROUND: Throughout the early part of this century, the person charged with repairing and/or oiling books for the rare book library or the general collection was invariably housed in the basement or attic or hidden somewhere in the stacks; this was true even at the Library of Congress. In the majority of cases, these people were very poorly paid and in some situations they were volunteers. They were always under the complete control of the librarian or curator. Decisions regarding choice of materials, color, style, and degree of treatment were in most cases made by the librarian. This scenario existed for many years and still does in certain institutions. In the 1970's, however, a dramatic change took place with the advent of the book conservator and the development of this profession, alongside an explosion of material in the literature on all aspects of custodianship of rare book and manuscript collections including environment, shelving practices, rehousing of collections, treatments, etc.

All this activity had a strange effect on the scholar/librarian. He backed off from making preservation decisions and became less and less involved in the day-to-day work of the new animal that had invaded his territory. So in a very short period of time, libraries went from what we might call a "dogmatic librarian" to a "dogmatic conservator" scenario. Being a strong-willed conservator myself, I would now like to advocate a middle road. The time has come when professional book conservators must regain the counsel of librarians/curators in all the various areas of scholarship relative to the rare book and manuscript field. Otherwise, decisions may be made by the conservator based primarily on the condition

## CONSERVATOR AND LIBRARIAN

of the item without sufficient weight given to other criteria. The areas that need to be discussed, in person and in print, by the scholars and curators of rare book and manuscript collections include the following issues:

1. The addition of modern material to early books.
2. The disruption of the text block or the removal of attachments, pins, or clips to manuscripts prior to conservation treatments.
3. The effect of treatment of text blocks, e.g. washing, alkalizing, reducing stains, sizing, etc. on evidential value.
4. Collation practices by conservators.
5. The suitability of structural changes to improve a poor original structure (Book of Kells).
6. Removal of a 20th Century rebinding from a 16th Century book; e.g., a binding by Sangorski and Sutcliffe.
7. Decorating the binding of an early book with a modern typeface or modern decorative tools.
8. The boxing and rehousing of entire collections.
9. The development of good professional relationships between librarians and conservators.

### 13. COLLATION PRACTICE

Ordered pages are vital to the workings of a book and the importance of correct and clear collation<sup>(1)</sup> in large conservation shops can never be overstressed. Books of different periods and cultures create an enormous variety of methods in denoting the sequence of leaves through a book and this is a complex study in itself. The conservation workshop system chosen must be simple and flexible to cope with all possible contingencies and be easily understood by all concerned.

An underlying principle governing our collation policy is that all leaves (Fig. 1) belonging to the text-block are notated with numerals (Arabic or Roman) and the leaves added by a binder are notated by using capital letters. (Fig. 2)

Fig. 1 (1 folio=2 leaves= 4 pages)

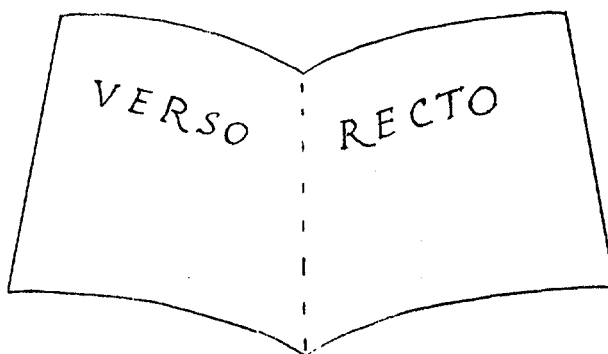
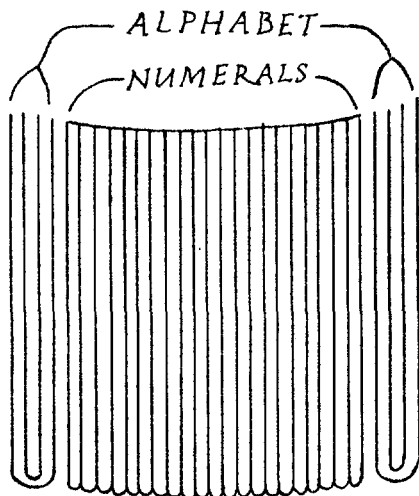

Fig. 2



The general practice is to use a soft pencil keeping it pointed to form small and precise numerals in the top fore-edge margin of Page (2). Books reading in the Oriental manner should be collated and numbered in that manner and the above instructions for Occidental books may be happily reversed. (Fig. 3). Normally penciled collation will be preserved and continued in use as a benefit to the reader therefore it must be carried out with extreme accuracy and in consultation with the custodial division.

The actual "make-up" of the signature (sections/gathering) of a book will be noted on the "Historical Record Card" and possibly several different systems will be used. One method which will occasionally appear on the "Work Specification Cards" dealing with

Fig. 3

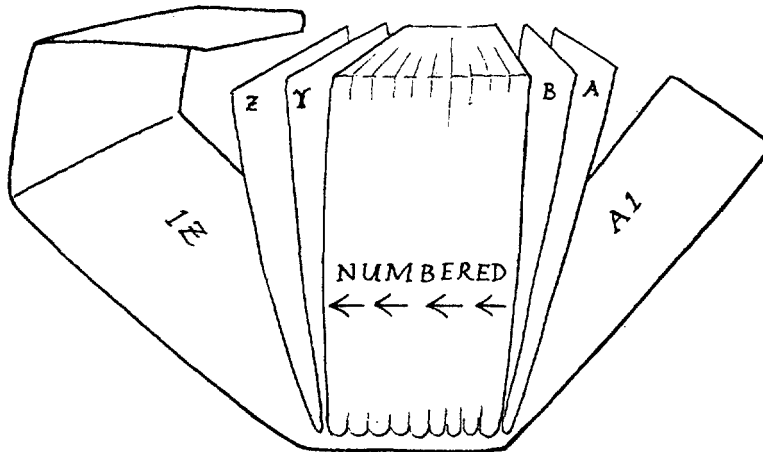

books in poor order, is the following system noting "make-up" of each signature, large figure denotes signature, small figure the number of leaves in signature, example:-

1-4<sup>8</sup>, 5<sup>7</sup> (2nd leaf hooked), 6<sup>6</sup> (4th & 5th leaves missing), 7-10<sup>8</sup> end.

For ease in identification whilst in the conservation areas and for the even more important function of referring back to the conservation techniques and materials used. The conservation number will be penciled at the center of tail margin on the verso of the last printed page.(3)

Where the scribe or printer has numbered by leaves (folioed) only, this is followed by collator, indeed this is the preferred method; but where he has paginated (numbered by pages) any unnumbered leaves are continued by pagination. Where printers numbers are not continuous or text-block is made-up of several books each with a separate group of numbers then clarity must reign, either pencil numbers link up between books (Fig. 4) or, where no easy follow through is possible then collation may have to start from leaf or Page 1 and continue through whole text-block. When any unusual variations are used these will be explained on the reverse of the "Work Specification Card" under "No. 13".

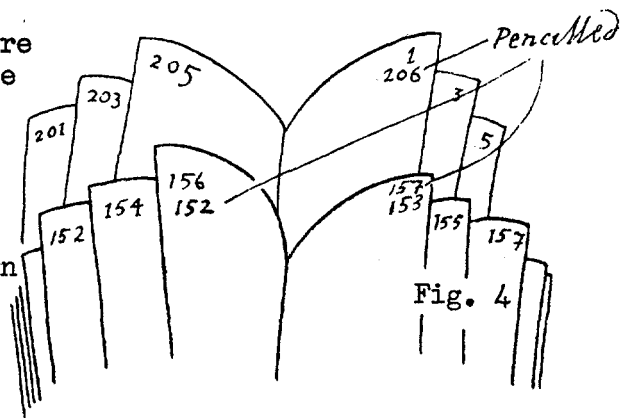

This workshop will use only Arabic or Roman numerals for their collation and interchange between them, e.g. if say first leaves of text-block are not numbered but text starts in Roman numerals then one would use Arabic until the Roman begins and visa-versa. Always overlap by one page in such circumstances (Fig. 5), by connecting such numbers one clarified that there were no intervening leaves at the time of collation.

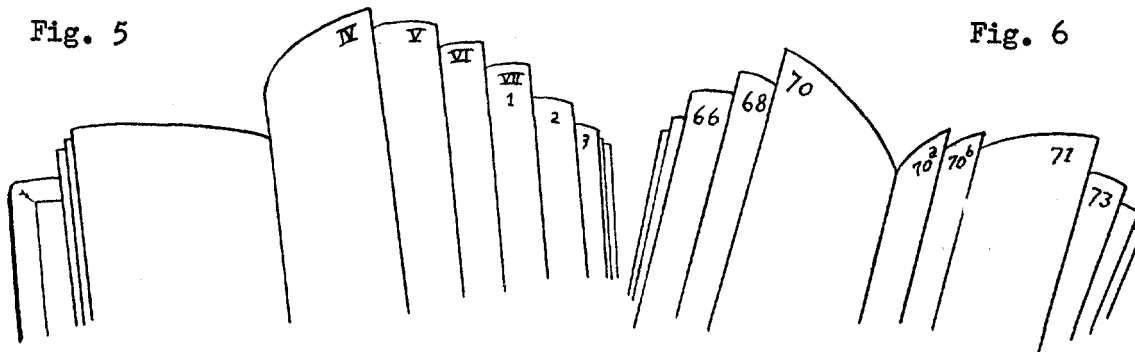

Where printed or written numbering is incorrect cross out lightly in pencil and place correct number above it, where leaves are in wrong order this must be checked with custodial division before rearranging.

Where stubs occur naturally through the text-block they should be notated with the same number as the preceding leaf (or page) followed by a lower case "a", "b", "c", etc. (Fig 6) where leaves have been cut or torn out and a stub is left this should be numbered as a complete leaf. (Fig. 7)

Any loose inserts, plates, maps, etc. should be numbered as the preceding leaf or page followed by a lower case letter, a, b, c, etc. (Fig. 8 & 9). Any single or layered tipped plates, cuttings, etc. should be numbered the same as the supporting page. A treatment similar to collation method used when dismantling layers on inside of boards (Fig. 10, also see Page 4). The number of the

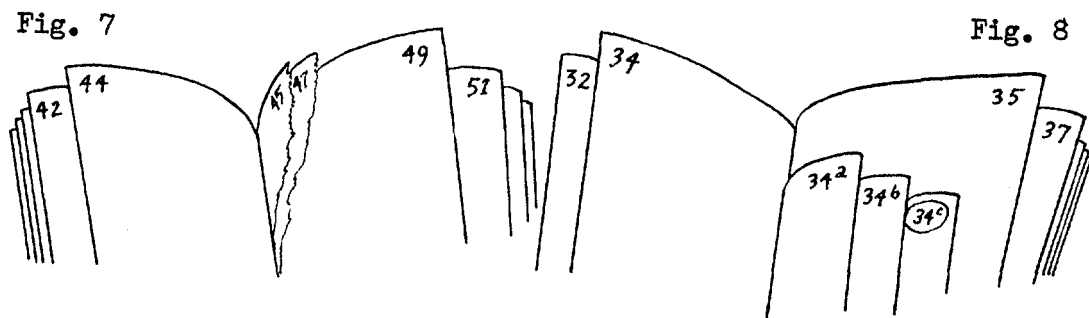

last sheet in that group is circled so that one will know if a sheet has been mislaid during the rebinding operation (Fig. 8 & 9). By the way, always check the number and position against a volume's list of illustrations (if it has one) and make a clear note of any missing or additional plates.

Fig. 9

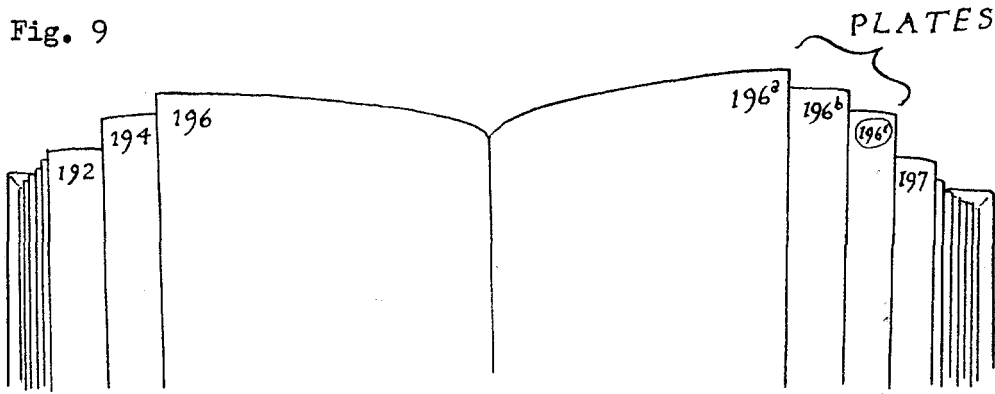

Problems relating to the physical position of clippings or cuttings on a page may be solved (if custodial division deems it important) by taking xerox copies or photos of those pages, if possible, after "pulling" but before further treatment. Clippings or cuttings pasted in layers on a page are collated by the page number they are attached to plus a lower-case letter starting with 'a' and proceeding in towards page as they are uncovered (Fig. 10).

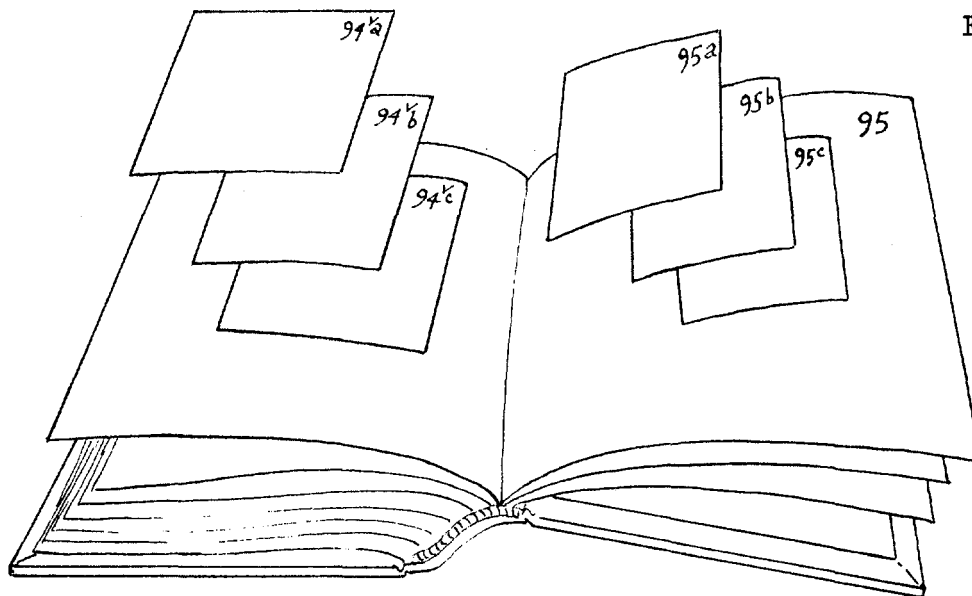
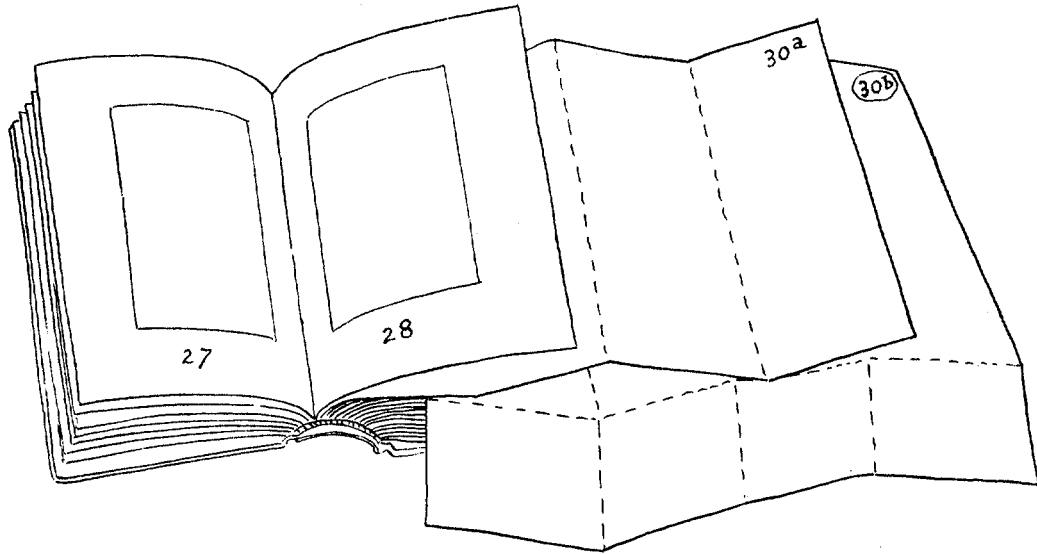

Fig. 10

Folded plates or maps can be confusing to collate and to the rebinder sometimes a mystery even to know which side was the spine edge, so we must be extra careful with their collation. The simplest rule is to always fully open out plate and number it in the top right hand corner on the recto side of sheet (Fig. 11) even when the illustration is on the verso side.

Fig. 11



One would like to refold such plates back into their original folds, these can be marked on reverse of plate at extremities of each fold with the following symbols, a valley fold has a simple stroke down center of fold, (so that exact placing of fold can be determined) a mountain fold has a similar stroke plus a cross curved stroke as a differentiation. (Fig. 12)

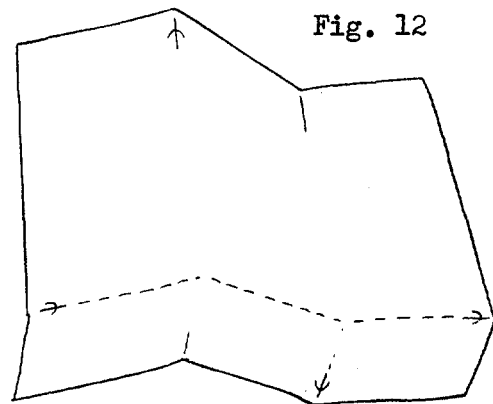

The leaves added to the text-block by previous binders are treated separately and notated by using capital letters in the following manner. On opening the upper cover the first free fly leaf (whether this is the paste-down or not), is lettered "A" and the following are "B", "C", "D", etc.



During restoration if any endpapers or interesting paper fragments used in paste-boards are covered then these must be notated in pencil by numbering 1A, 2A, 3A, etc., as they are being uncovered from inside of board to outside. (Fig. 13, note the use of a lower case "v" to indicate "verso" in illustration).

Fig. 13

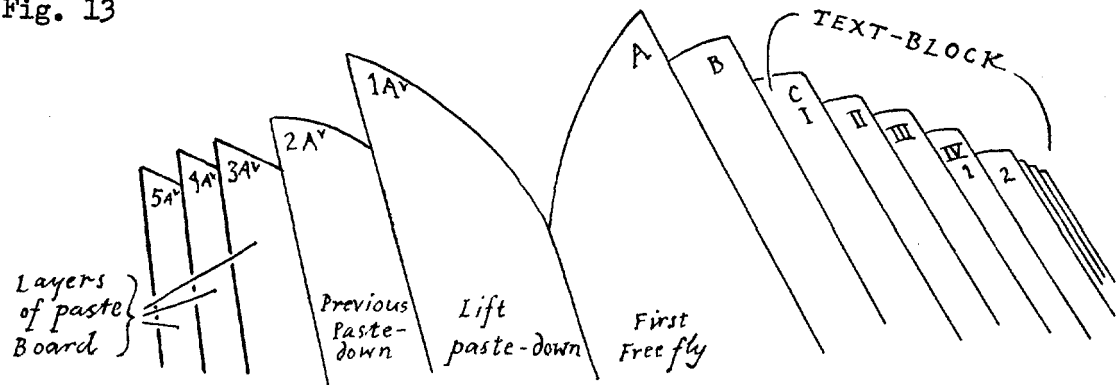

The exact reverse of this form of collation is used at the other end of book, that is when opening the lower cover the free leaf is "Z" and the ones towards the text-block are Y, X, W, etc., while any notation of board and paste-down is Z1, Z2, Z3, etc., proceeding from inside lower cover to outside.

All fragments of the binding such as clasps, spine liners, pieces of leather, etc., must be also carefully marked so that their exact position will be known afterwards. This, of course, lends itself to such a large variety of problems that it is difficult to get a simple procedure to follow; so we will have to use a visual one, such as a thumbnail sketch or photographs (with the various items numbered to form a key if need be) except with spine liners where we can often number items in the order from head of spine to tail, mark number at head and on the exterior side of each piece. (Fig. 14)

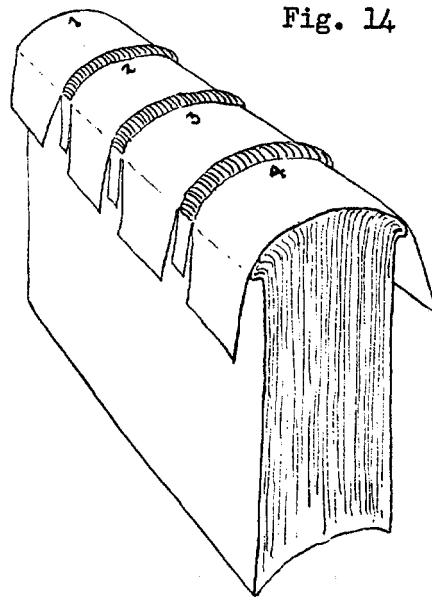

Fig. 14

- 1) See Appendix I - Carter, John, 1905 -, "ABC For Book-Collectors", London, R. Hart - Davis, 1952.
- 2) An exception to this rule occurs when a leaf has been mended for one would never number over a repair; in such a case one numbers in the head or fore-edge margin (always on the original document) as close as possible to the top fore-edge margin of the page.
- 3) The minimum amount of written numerals will be used and always in one straight line; this is a promise to custodians in the hope that they will not erase this important cross-reference mark to our card system which explains what has been done, when it was done, condition before it was done, etc. This number is added after "Reception".

## APPENDIX I

ABC For Book-Collectors, John Carter

...In the sentence, 'this copy has been collated with the one in the British Museum', the cataloguer is using the word in its simpler sense of 'to compare'; and the implication is that the two copies are of the same composition. When he pencils on the endpaper 'collated and perfect' (or simply 'c. & p. '), he is using it in the special sense of 'to examine the sheets of a printed book, so as to verify their number and order'. The operative word is 'verify'. Verify by what? If no bibliographical description of a book is available and no other copy for comparison, 'collation' in this sense can do no more than reveal obvious imperfections.

Yet once the collector has mastered the method in which the leaves of printed books are GATHERED, and the customary SIGNATURE marks by which the gatherings are identified by the printer for the binder, he can at least tell, even where there are no page numerals, whether any leaves are missing from the body of the book. The preliminary leaves are more tricky: for being generally printed last and comprising such variable features as HALF-TITLE, list of contents, dedication, etc., they are not always of straight-forward composition, and often are not signed at all.

But collation has acquired a further, and to most collectors more familiar, connotation: the bibliographical description of the physical composition of a book, expressed in a more or less standardised formula. (Formula, or formulary, is in fact becoming the fashionable term, especially among American bibliographers.) The collation, in this sense, consists of three parts: an indication of the FORMAT, the REGISTER OF SIGNATURES, and a record of the number of leaves. Thus '8vo A-L<sup>8</sup>M<sup>4</sup>' means an octave volume of 92 leaves, gathered in eleven quires of eight leaves and one of four: there is no J (or U or W) in the European signature alphabet, though these letters are sometimes found in 19th century American books. This is an extremely simple example; and in order to show what a collation can look like, here is a notional one published in *The Book Collector* (vol. 1, no. 4) as a test for its bibliographical readers: 'Quarto: ~~r~~4\*2A4B-C4 (C<sub>3</sub>+X<sub>2</sub>) D-G4(±G<sub>2</sub>)H4(-H<sub>2.3</sub>,=\*2).' Dr. Gaskell's expansion of this formula is as follows: 'An unsigned four-leaf section, the first leaf conjugate with the fourth and the second with the third (henceforth a "quarto section"); followed by a conjugate pair of leaves signed with an asterisk; followed by an unsigned quarto section (given the inferential

signature A); followed by two quarto sections signed "B" and "C" respectively, in the second of which the third leaf is followed by an inserted unsigned conjugate pair; followed by four quarto sections signed "D", "E", "F" and "G" respectively, in the last of which the second leaf has been removed and replaced with a cancellans; followed by a quarto section signed "H", the central conjugate pair of which (i.e. H2.3) was signed with an asterisk, and removed to become the second section of the preliminaries, noted above. (It is assumed that this state of affairs can be proved by the existence of a copy with H2.3 in its original position). From this it may be seen that the collector who aspires to understand the collation of earl books—complicated by HALF-SHEET imposition or gathering, unsigned quires, INSERTED single leaves (or SINGLETONS), CANCELS and so forth—must brace himself to a thorough study of MCKERROW, probably also of Fredson Bowers's *Principles of Bibliographical Description* (1951) and perhaps even of Greg's introduction to vol. IV of *A Bibliography of the English Printed Drama to the Restoration* (1959).

He will note meanwhile certain shorthand conventions; e.g. that  $P_4$  means a four-leaf gathering signed P, whereas  $P_4$  (or sometimes  $P_4$ ) means the fourth leaf of the gathering signed P; that the RECTO and VERSO of the leaf are distinguished by some bibliographers as  $P_{4r}$  and  $P_{4v}$ , by others as  $P_{4a}$  and  $P_{4b}$ ; that among the older bibliographers unsigned leaves or gatherings are recorded as [P] if the signature letter can be inferred, as [ ] or [-] if it cannot; that the new school use  $\pi$  for unsigned PRELIMINARY leaves or gatherings,  $\chi$  for unsigned leaves or gatherings inserted in the body of the book, and an italic capital letter for an inferential signature. He will further bear in mind that collation takes account only of those leaves of the book which were delivered to the binder by the printer. It includes, that is to say, any BLANK LEAVES or leaves of ADVERTISEMENTS forming part of the gathered sections of the book; but it excludes ENDPAPERS, binder's blanks, inserted advertisements, etc.

It will be seen that collation by signatures, which is the only scientific method of describing the physical make-up of a book, is a technical procedure governed by strict rules. For modern books, however, bibliographers obedient to the DEGRESSIVE principle have evolved various simplified formulae, more or less adequate to their material but not yet unfortunately (except in the *Soho Bibliographies* series) standardised.

#### FOLIATED, FOLIATION

Foliation is the numbering of leaves, as opposed to PAGINATION, which is the numbering of pages. It is rare in books printed before 1475, when the majority bore no consecutive numeration at all; or after 1600, by which time it had generally given place to pagination.