

LED Replacements for Four-Foot Linear Fluorescent Lamps

Linear fluorescent lamps are widely used in commercial spaces such as offices, schools, hospitals, and stores. Ever-increasing numbers of LED replacement products are available on the market. To make informed purchasing decisions, lighting users should compare the performance of LED replacements for linear fluorescent lamps on the basis of light output, distribution, color quality, energy efficiency, and cost-effectiveness.

The most common linear fluorescent lamps are nominally four feet in length, with bi-pin sockets and tubular T12 or T8 envelopes. Both T12 and T8 lamps remain common in existing buildings, but due to recent Federal efficiency standards, almost all new commercial construction uses T8 or T5 lamps. DOE's Commercially Available LED Product Evaluation and Reporting (CALiPER) program has tested LED products and the benchmark fluorescent lamps they claim to replace. Tests were performed both on bare lamps and with lamps installed in lensed or parabolic-louvered troffers. CALiPER tested four LED replacement products in 2008, eight more in 2009, and another six in 2010. While average light output and efficacy have increased over these rounds of testing, LED replacements still do not match the output or intensity distribution of standard four-foot linear fluorescent lamps.

As shown in Figure 1, currently available LED replacement products do not match the measured light output of benchmark four-foot linear fluorescent lamps. For the six LED replacements most recently tested, average bare lamp light output was 48% of the benchmark fluorescent lamp, and the highest-output LED replacement produced just 58% of the benchmark.

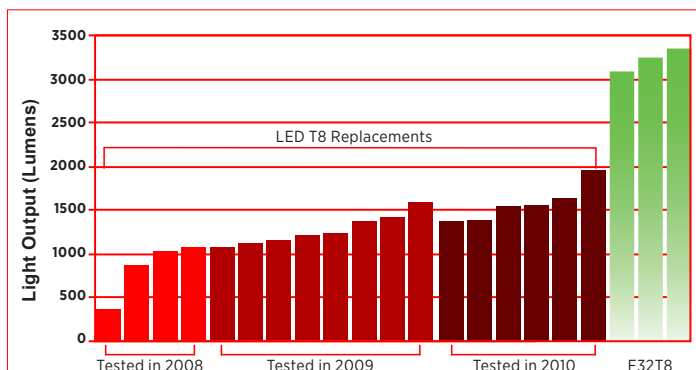

Figure 1: Measured light output (lumens) for four-foot LED and fluorescent lamps tested by CALiPER



Most LED replacement products emit light from one side of the lamp, using the other side for thermal management.

Courtesy of PNNL

Operation in Recessed Troffer Fixtures

One challenge facing LED replacements relates to the optical characteristics of fixtures that are designed to harness the omnidirectional output of fluorescent lamps. When fluorescent lamps are mounted in troffers, a portion of their total light output is directed into the fixture. Most fluorescent troffers utilize reflectors to efficiently redirect this light out of the troffer. Louvers and/or lenses can then provide additional control, while also shielding the lamps from direct view and reducing glare. These optical components affect the percentage of bare-lamp output (adjusted for actual ballast factor) that exits a fixture. This percentage (known as the luminaire efficiency) is directly related to luminaire efficacy, which is calculated by taking the ratio of troffer light output and troffer input power (expressed in lm/W).

Figure 2 illustrates how the directionality of a light source may affect luminaire efficiency. Lamp A represents a typical linear fluorescent lamp, such as a T8 or T12; lamps B and C illustrate the more directional output of LED replacement products. Little to none of the light from LED replacements is directed into the fixture, so troffers using LED replacement products in lieu of fluorescent lamps often have higher efficiencies, but workplane light levels and uniformity may be inadequate.

Intensity Distribution and Light Output

Lensed troffers generally shape emitted light in a cosine or teardrop-like distribution (Figure 3). CALiPER found that lensed troffers lamped with LED replacements produced narrower distributions and significantly lower luminous intensity values. Meanwhile, parabolic-louvered troffers are designed to produce a “batwing” distribution (Figure 4). CALiPER found that parabolic-louvered troffers lamped with LED replacements produced comparable luminous intensity near nadir, but fell short of fluorescent at higher angles.

A batwing distribution allows for a wider spacing of fixtures because the center intensity (at or near nadir) is lower than at the higher angles, creating more uniform lighting. In contrast, a cosine distribution focuses the intensity below the fixture requiring more fixtures and closer spacing to achieve uniform illumination.

The narrower distribution produced by troffers lamped with LED replacements may not provide adequate workplane uniformity. The illuminance directly below the fixture may actually increase, but if the existing fixture layout remains unchanged, compromised uniformity could result in noticeably dark areas between fixtures. More fixtures and LED replacement products may be required to match the overall illuminance levels and uniformity of lensed or parabolic-louvered troffers fitted with fluorescent lamps, resulting in increased cost and reduced or negated energy savings.

As shown in Table 1, the parabolic-louvered troffer lamped with LED (in lieu of fluorescent) drew 25% to 50% less power, but these savings were largely attributable to the corresponding 20% to 31% reductions in light output. Similarly,

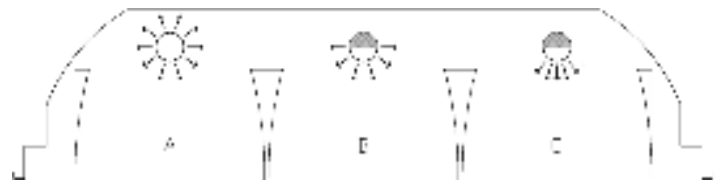

Figure 2: Cross section of three-lamp troffer fixture showing light distribution of a linear fluorescent (A) vs. LED replacement lamps (B and C)²

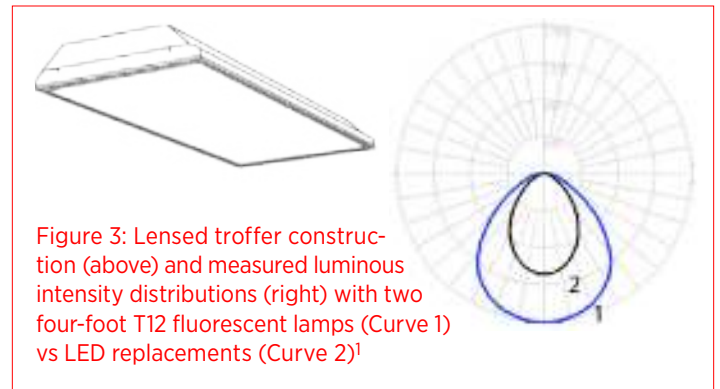

Figure 3: Lensed troffer construction (above) and measured luminous intensity distributions (right) with two four-foot T12 fluorescent lamps (Curve 1) vs LED replacements (Curve 2)¹

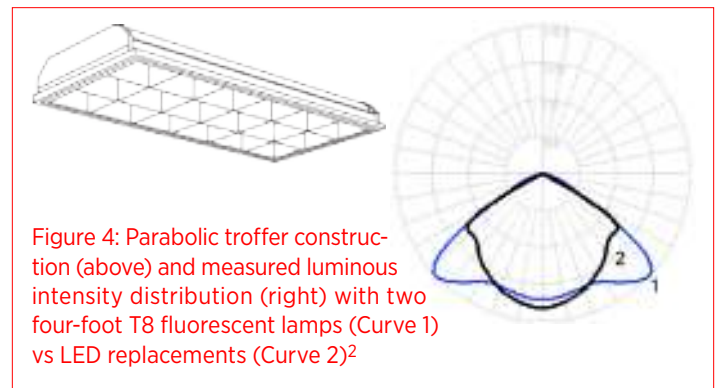

Figure 4: Parabolic troffer construction (above) and measured luminous intensity distribution (right) with two four-foot T8 fluorescent lamps (Curve 1) vs LED replacements (Curve 2)²

Table 1: Four-Foot Linear Fluorescent Lamps and LED Replacements in Parabolic Louver and Architectural Lensed Troffers

	Parabolic-Louvered Troffer		Architectural Lensed Troffer	
	2 FL T8s	2 LED T8s (range for 3 LED products)	2 FL T8s	2 LED T8s
Total Power (watts)	58	29–43	55	29
Output (initial fixture lumens)	3675	2173–3247	4045	2217
Fixture Efficiency	68%	79–83%	62%	81%
Luminaire Efficacy (lumens/watt)	63	57–75	74	77

Source: CALiPER Testing Rounds 9 and 11

¹ Source: CALiPER Performance of T12 and T8 Fluorescent Lamps and Troffers and LED Linear Replacement Lamps Benchmark Report (Jan 2009)

² LED curve from CALiPER Round 11 Summary Report.

while the efficiency and efficacy of an architectural lensed troffer were higher when LED replacements were used in lieu of fluorescent lamps, light output was nearly halved.

Color Characteristics

Color characteristics were also recorded during CALiPER testing of these products. Correlated color temperature (CCT) indicates the color appearance of a light source, whereas color rendering index (CRI) provides a measure of color fidelity relative to a reference source having a “perfect” CRI of 100. Most linear fluorescent lamps range from “warm” light of about 3000 Kelvin (K) to “cool” light of about 4100K, and often feature a CRI above 80.³

Of the six LED replacement products most recently tested, three exhibited CCTs above 5000K, while the others ranged from 3200K to 4300K. Meanwhile, CRI values ranged from 65 to 77 for the six LED replacement products (77 being the highest measured by CALiPER to date), versus 82 for the benchmark fluorescent lamp. Three LED products had chromaticities outside ANSI tolerances for white light, indicating these products may appear greenish or pinkish in color.⁴

Electrical Modifications

Another important consideration when replacing linear fluorescent lamps with LED products is electrical safety. Nearly all LED replacements bypass the existing ballast. Most have their drive electronics integrated in the tube, while some are provided with external drivers that replace the existing fluorescent ballast. Bypassing the existing ballast results in line voltage being delivered to the sockets (“tombstones”) in the fluorescent fixture, creating a hazard if a fluorescent lamp is later re-installed in that same fixture. If a fixture is modified such that it can no longer accept its original lamp, it must have a label affixed (provided by the LED replacement manufacturer) clearly indicating this condition. In addition, UL has issued special requirements for fixtures with “shunted” sockets, i.e., those that use instant-start ballasts. Since LED replacements may be certified under different product safety standards (UL or CSA), purchasers should ask manufacturers and lamp vendors about compliance with applicable safety standards.

Useful Lifetime

LED replacement lifetime projections are generally based on the estimated hours for light output to degrade to 70% of initial output (i.e., L70). Manufacturers commonly claim L70 lifetime values of 35,000 hours or more. Longer lifetime translates into fewer relamping cycles, which offsets the higher initial cost of LED products. Linear fluorescent lamps on the market have rated lifetimes ranging from 24,000 to more than 42,000 hours, depending on switching frequency and the type of ballast used. In addition, fluorescent T8 lamps have very high lumen maintenance, producing approximately 92% of initial output at end of life. Given that CALiPER testing indicates the initial light output of LED replacements does not meet fluorescent benchmark performance, an L70 life definition for LED only widens the performance gap.

Cost Effectiveness

LED replacement prices have declined in the past year but still vary significantly. Prices for the most recently tested products ranged from \$62 to \$120 per lamp. Larger volume purchases may result in lower unit costs. A fair cost analysis should compare LED replacements to fluorescent lamps on the basis of equivalent lighting performance. Table 2 compares costs and performance under two scenarios, retrofit and new construction. Both examples assume a 30’x30’ room illuminated by two-lamp parabolic-louvered troffers, and three possible prices for LED are considered: \$30, \$70, and \$120 per lamp.

Section A shows costs in lamps and fixtures alone (not including labor costs) to light the space to an average maintained illuminance of 35 footcandles (fc), considered adequate for performance of visual tasks of high contrast and large size. This requirement would be met by 13 troffers lamped with fluorescent, versus 17 to 25 of these same troffers lamped with LED replacement products. Lighting power density (LPD) would be comparable but cost per square foot would be 2 to 5 times higher for LED. If expected lifetime is equivalent and there are no energy savings, the payback period would be infinite.

³ The Consortium for Energy Efficiency (CEE) specifications for T8 fluorescent lamps require a CRI of 80 or greater. Prior to the Energy Independence and Security Act of 2007, the definition of general service fluorescent lamps (GSFL) excluded lamps with a CRI of 82 or greater. Effective June 22, 2011, GSFLs with a CRI less than 87 must be certified as compliant with the applicable Federal efficiency standard.

⁴ See criteria for Duv in ANSI_NEMA_ANSI C78.377-2008, American National Standard for Electric Lamps—Specifications for the Chromaticity of Solid State Lighting (SSL) Products.

Table 2: Fluorescent T8 Compared to LED T8 Replacement Lamps at 3 Example Unit Prices

Source	Fluor T8 \$3 per lamp	LED \$30 per lamp	LED \$70 per lamp	LED \$120 per lamp
Total Price (lamps+fixture)	\$131	\$185	\$265	\$365
Input Power per Fixture	58	36	36	36
Output per Fixture	3675	2710	2710	2710
A. New Construction – Target maintained illuminance 35 fc, 900 square foot space				
Number of Fixtures	13	21	21	21
Cost per Sq Ft (lamps+fixtures)	\$1.89	\$4.37	\$6.27	\$8.63
Lighting power density (W/sf)	0.84	0.85	0.85	0.85
Simple payback period (years)	infinite (no energy savings)			
B. Retrofit – 13 fixtures, 900 square foot space				
Average Maintained Illuminance	34	22	22	22
Cost per Sq Ft (lamps only)	\$0.09	\$0.87	\$2.02	\$3.47
LPD	0.84	0.52	0.52	0.52
Simple payback period (years)		8	19	33

NOTE: Figures are rounded for legibility. LED output and wattage figures are averages of two LED T8 replacement lamps tested in July 2010. Luminaire outputs and efficacies for these products when measured in a 2'x4' parabolic troffer were 2173 at 74 lm/W, and 3247 at 75 lm/W. Corresponding CRIs and CCTs were 77 at 5389K, and 71 at 5253K. Actual prices were \$62 and \$83 per lamp, respectively.

Section B shows the costs of replacing fluorescent lamps with LED products in an existing layout of 13 fixtures. LPD and annual energy use would be approximately 38% lower for LED, corresponding to a 35% reduction in average light levels. Cost per square foot would be 10 to 40 times higher for LED, and the energy savings would yield a simple payback period of 8 to 33 years.

Summary

LED replacement products have improved in light output and efficacy but do not appear to provide equivalent light output, color quality, distribution, or cost-effectiveness, compared to four-foot linear fluorescent lamps. DOE will continue to monitor and report on developments in this product category.

A Strong Energy Portfolio for a Strong America

Energy efficiency and clean, renewable energy will mean a stronger economy, a cleaner environment, and greater energy independence for America. Working with a wide array of state, community, industry, and university partners, the U.S. Department of Energy's Office of Energy Efficiency and Renewable Energy invests in a diverse portfolio of energy technologies.

More Information

For SSL Program information visit www.ssl.energy.gov.
Direct fact sheet feedback to SSL.Fact.Sheets@pnnl.gov.